



# OPTONICA

10000 DM

## RX-1 PCM Digital Audio Adaptor



The RX-1 unveils a completely new audio era with a wide range of features and unique, innovative ideas.

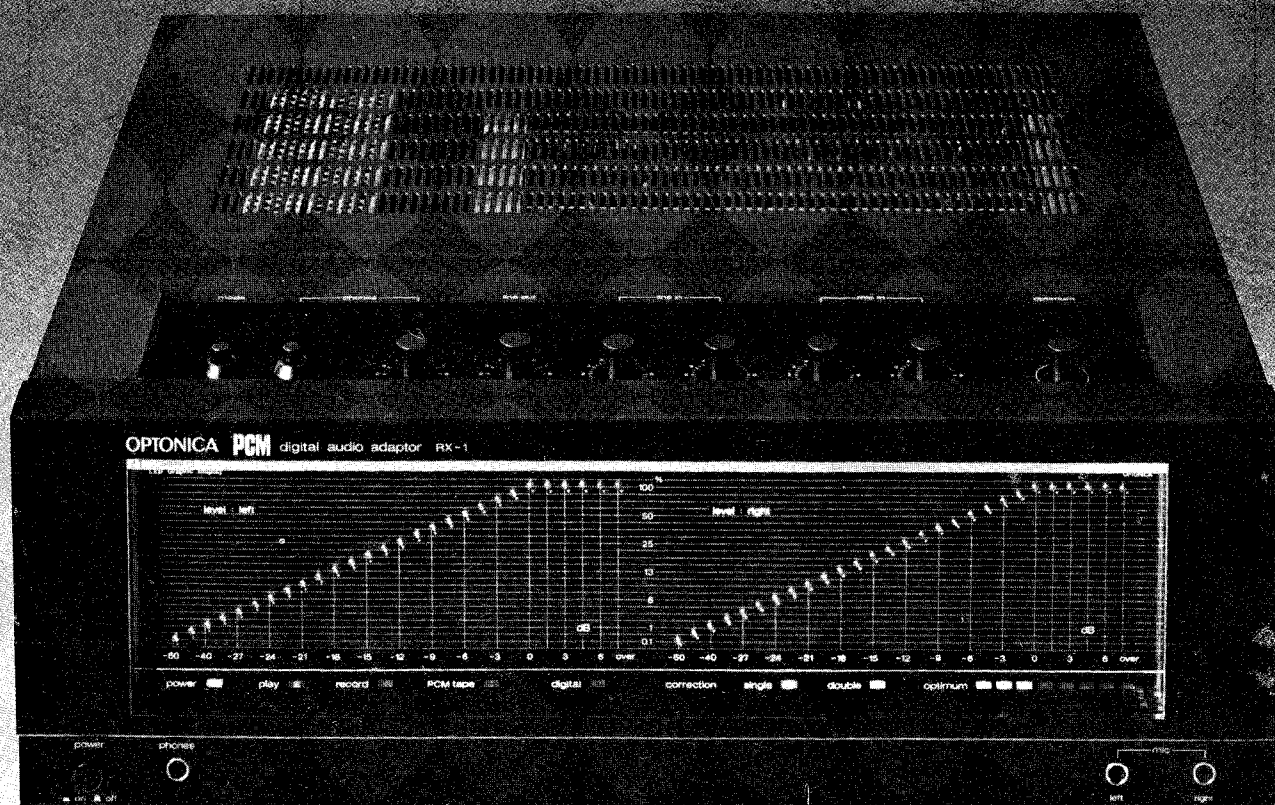

## A Dream Unit for Adventurous Audiophiles

Sharp's advanced digital technology is backed up by innovative semiconductor technology. This has been combined with its sophisticated audio system expertise, well demonstrated in the OPTONICA series.

Now, OPTONICA is announcing a new audio era with the introduction of a dream unit - PCM digital audio adaptor RX-1. Throughout its continuous, relentless efforts in this field, OPTONICA has developed the versatile, compact PCM adaptor which can easily be connected to any home video. Featuring its impressive breakthrough in drop-out proofing capability, the RX-1 is the ideal solution to "analog" audio barriers that critical audiophiles have long been confronted with.

The PCM (Pulse Code Modulation) system sets audio technology on a completely new course, well beyond conventional analog audio. It is the system which converts analog signals into digital signals for storing the data on the videotape. First, sound signals are microscopically divided and then encoded into either 1 (presence) or 0 (absence) and recorded onto

videotape. This eliminates noise which could very often be mixed with the music signals at the time of recording.

### Adaptable to Any Type of Video Cassette Recorder

Having adopted Optimum Control function, the RX-1 permits you to search for the ideal matching point, best suited to any type of video cassette recorder, VHS or Beta. This means that the ingenious unit promises you spectacular sound quality anytime, anywhere.

The adaptability level is conveniently displayed on LED indicators for your quick, accurate reference.

### OPTONICA's Unique Drop-Out Proof System with 99.995% Perfection

OPTONICA, by fully utilizing a sophisticated memory function, has developed a superb drop-out system for dutiful, accurate reproduction of the original sound. Necessary data for drop-out proofing are input at the time of recording. Then at the time of playing, correction is done to near perfection. The result is a stunning 99.995% correction capability.

## The way to record or reproduce on PCM

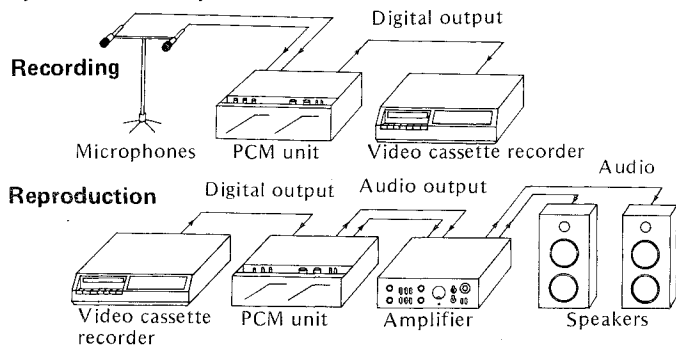

## Blocks of the PCM unit

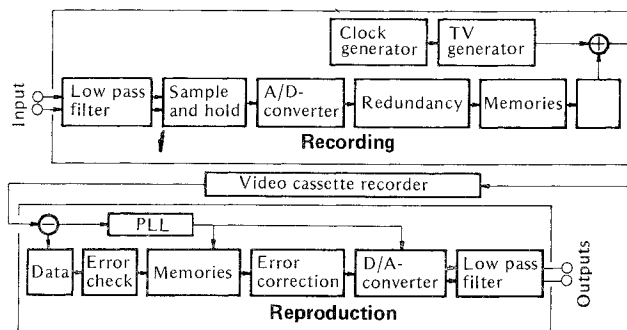

## Compact and Light, Culmination of Modern Designing

Unlike the general concept that PCM adaptors are bulky and heavy, OPTONICA's RX-1 is as compact as a stereo amplifier, weighing only 15.5 kg. Sharp's innovative semiconductor technology has changed the whole concept.

## Stunning 90dB Dynamic Range

Digital recording system means very low distortion and noise, resulting in a stunning 90dB dynamic range, thanks to 14-bit quantizing.

## Extra High Fidelity Recording and Playback

Because the audio signals are converted into pulse codes for recording and playback, the sound signals are not affected by rotary mechanisms characteristic to analog systems. The result is an extremely high fidelity in recording and playback, beyond any possibilities of the analog system.

## Accurate, Easy-to-Read LED Level Meter

28 LED level meter on one channel permits precise recording levels.

## Easy to Connect to Various Kinds of Equipment

In addition to PIN jacks, the unit includes cannon connectors and M type connecting jacks, for easy connection of the RX-1 with various kinds of equipment.

## Special Control for Precise Adaptability of PCM Adaptor to Videotape.

## Jack for Digital Direct Dubbing.

## Other features

- ★ Mike mixing.    ★ Gold plated PIN jacks.
- ★ Headphone jack.

## Data formats

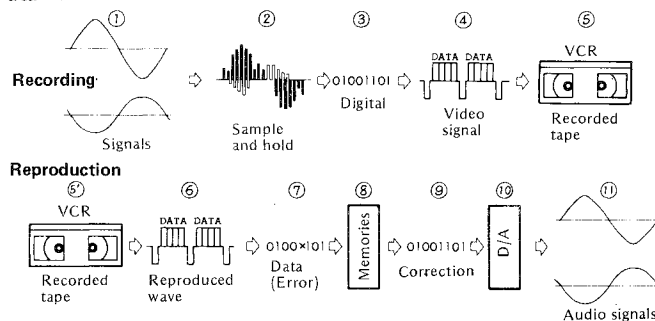

### Playback waveform of 10 kHz

Cassette tape deck

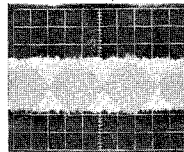

Open reel tape deck

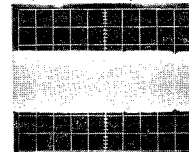

PCM system

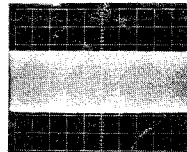

### Playback waveform of silent portion (50 dB or 300 times magnification on the scope)

Cassette tape deck

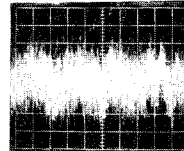

Open reel tape deck

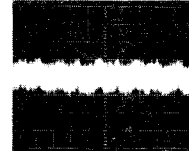

PCM system

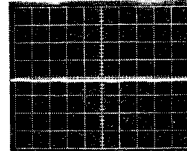

### Harmonic Distortion

Cassette tape deck

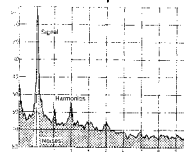

Open reel tape deck

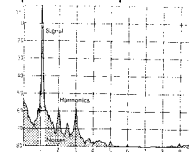

PCM system

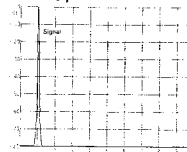

### Wow and flutter

Cassette tape deck

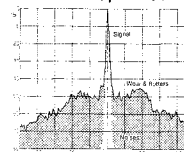

Open reel tape deck

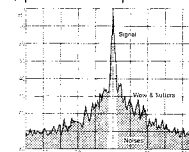

PCM system

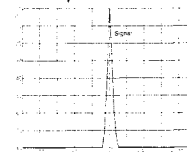



## Specifications

# RX-1

Power Source:	AC220V, 50Hz [AC 100V, 50/60Hz]*	Wow & flutter:	Below measurability
Dimensions:	430(W) x 141(H) x 360(D) mm	Harmonic distortion:	0.03% (1 kHz)
Weight:	15.5 kg	Dynamic range:	90 dB
Recording format:	PCM recording in PAL standard TV signals [NTSC standard]	Reproducing frequency range:	DC - 20 kHz
Transmission channels:	2 channels	Others:	Line input jack Line output jack Headphone jack Video input/output jack Digital signal input/output jack Dubbing jack External synchronized input/output jack
Sampling frequency:	44.100 kHz [44.056 kHz]		
Number of quantizing bit:	14-bit		
Data transmission rate:	2.625 Mbps [2.643 Mbps]		
Error correction capability:	99.995%		
Crosstalk:	More than 60dB (1 kHz, 10 kHz)		
Level variation:	Below measurability		

\* Note: Information in [ ] parentheses is for NTSC standard.

The manufacturer reserves the right to vary specifications, design, or use alternative materials as may be deemed necessary or desirable at any time, any such change or variation being of a kind as not to reduce quality, performance or appearance.

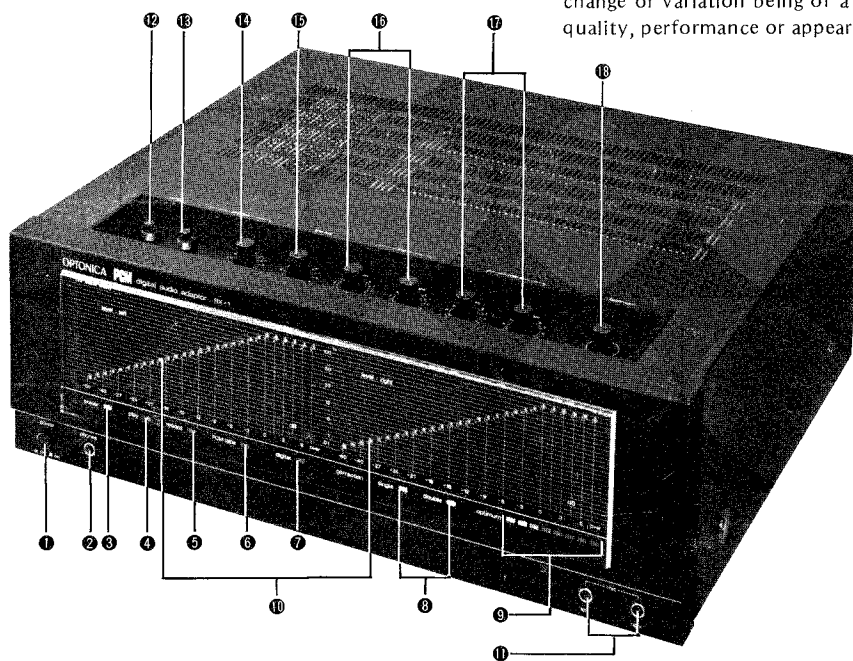

- |                      |                                      |                              |                             |
|----------------------|--------------------------------------|------------------------------|-----------------------------|
| ① Power Switch       | ⑥ PCM Tape Indicator                 | ⑩ LED Level Indicator        | ⑮ Line Output Level Control |
| ② Headphone Jack     | ⑦ Anti-Digital Dubbing Indicator     | ⑪ MIC Input Jack             | ⑯ Line Input Level Control  |
| ③ Power Indicator    | ⑧ Error Correction Signal Indicators | ⑫ Mode (Record/Play) Switch  | ⑰ MIC Input Level Control   |
| ④ Playback Indicator | ⑨ Optimum Indicators                 | ⑬ Error Monitor Switch       | ⑱ Optimum Control           |
| ⑤ Record Indicator   |                                      | ⑭ Headphone (Volume) Control |                             |



# OPTONICA

### Bezugsquellennachweis

**SHARP ELECTRONICS (EUROPE) GmbH.**  
SonninstraÙe 3, 2000 Hamburg 1, F.R. Germany  
Tel: (040) 28511 Telex: 2161867 HEEG D  
Telegram: SHARPEUROPA HAMBURG

**SHARP CORPORATION OSAKA, JAPAN**  
CABLE ADDRESS: LABOMET OSAKA  
TELEX: 63428 LABOMET A-D

# PCM DIGITAL AUDIO ADAPTOR

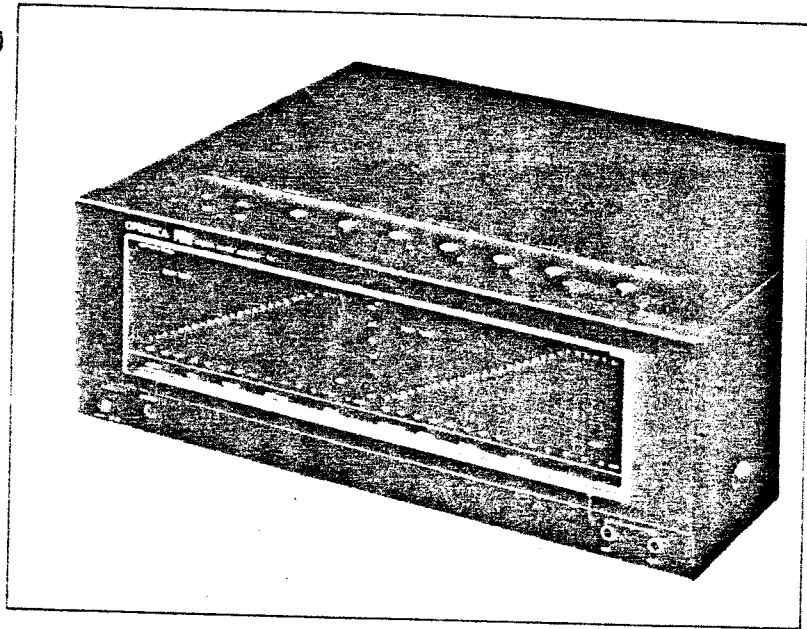

MODEL

**RX-1H**

---

 OPTONICA

OPTONICA  
PCM DIGITAL AUDIO ADAPTOR  
RX-1 H

CONTENTS

	Page
Contents .....	1
Features .....	2
Caution .....	2
Controls and Functions .....	3 - 4
Playback .....	5
Optimum Control .....	6
Recording .....	6
Dubbing .....	7
Connections .....	8 - 13
Specifications .....	14
Troubleshooting .....	15

**Note:**

Audio-visual material may consist of copyrighted works which must not be recorded without the authority of the owner of the copyright.  
Please refer to relevant law in your country.

**PCM Digital Audio Adaptor**  
**RX-1 PCM DIGITAL AUDIO ADAPTOR    OPTONICA**

Congratulations! You are now the owner of the OPTONICA RX-1 PCM digital audio adaptor. To fully appreciate the benefit of this quality audio product, it is advised that you read and thoroughly understand this operational manual before using.

**FEATURES**

- 1. Meets EIAJ (Electronics Industries Association of Japan) standard (625 line).**  
This digital audio adaptor is manufactured to meet the EIAJ standard arranged for 625 line areas and can be used on VHS, Beta, and U-matic formats.
- 2. Optimum control function**  
This control function maintains the RX-1 at the optimum playback performance level when used with any video cassette recorder. It compensates for a minor performance deviation in video cassette recorders.
- 3. Equipped with professional type connectors**  
Broadcast standard connectors such as cannon connectors and PL-259 type video connectors are used in addition to popular phono connectors.

**CAUTION**

**A Hint on Setting up the Equipment**

1. Position all equipment for easy operation.
2. Do not operate the unit in humid, dusty areas or expose the unit to extreme heat. A temperature of 30°C or below is recommended.
3. Use an appropriate voltage regulator in areas where voltage fluctuation is above average.

**Power Source**

The recommended power source for the unit is AC220V. Do not operate the unit except with AC220V. Otherwise, electrical failures and other hazards will result, including fire and electric shocks.

**Service**

There are no user-serviceable parts inside. In case of failure, take the unit to the nearest authorized dealer for repair.

**Maintenance**

Clean the unit with soft cloth and mild detergent. Never apply alcohol, paint thinner, or other harmful chemicals. These distillates will smear the casing or remove the paint.

**Dew Problem on a video cassette recorder**

1. Do not operate a video cassette recorder in areas where moisture condensation might occur. Moisture condensation may occur inside the unit after heating a cold room.
2. Please refer to an owner's manual of the video cassette recorder for further information on dew problems.

OPTONICA PIRE

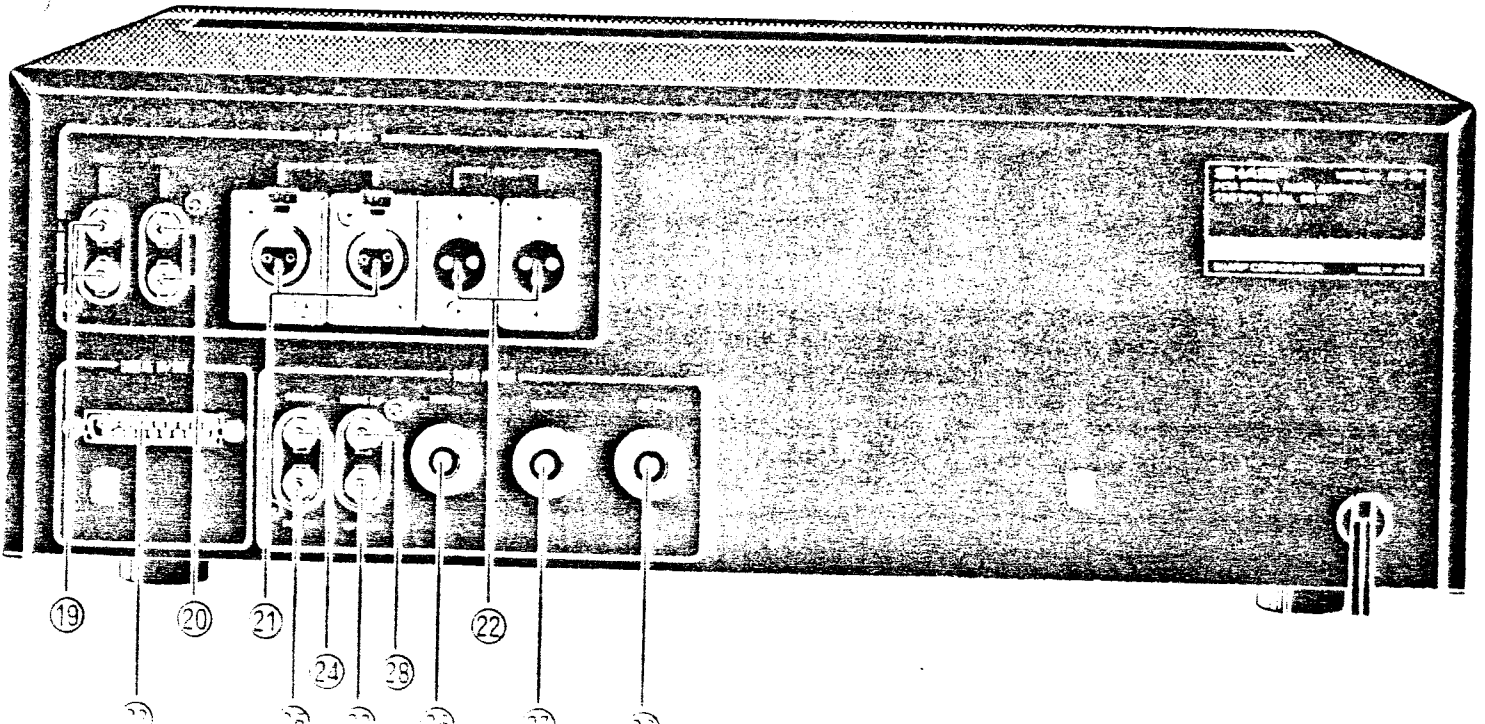
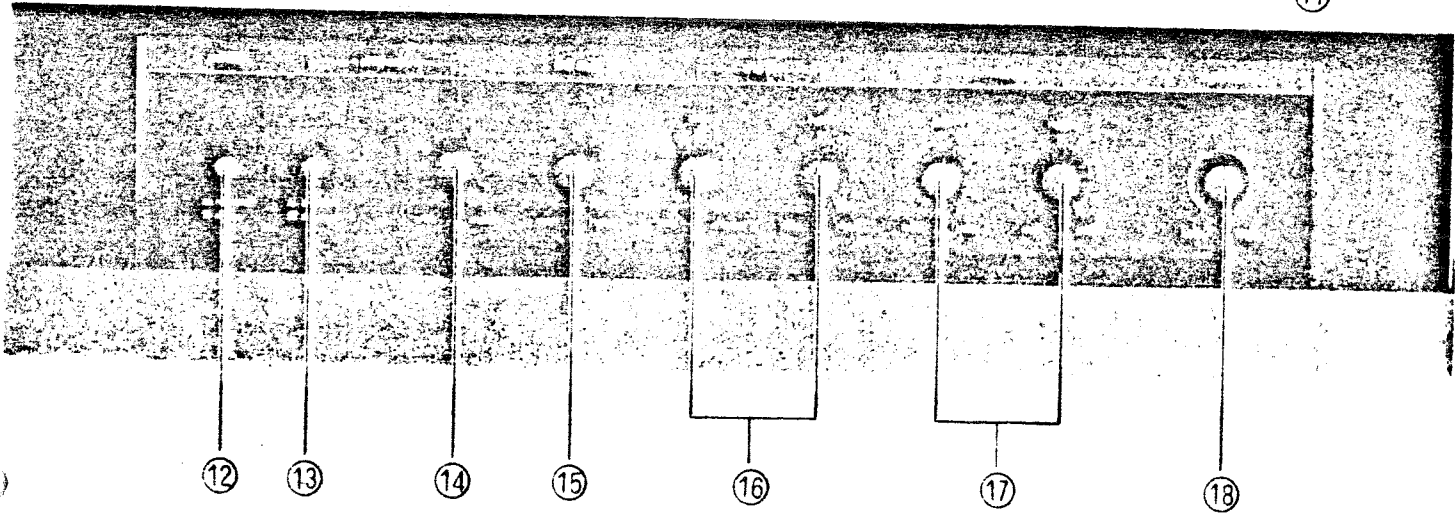
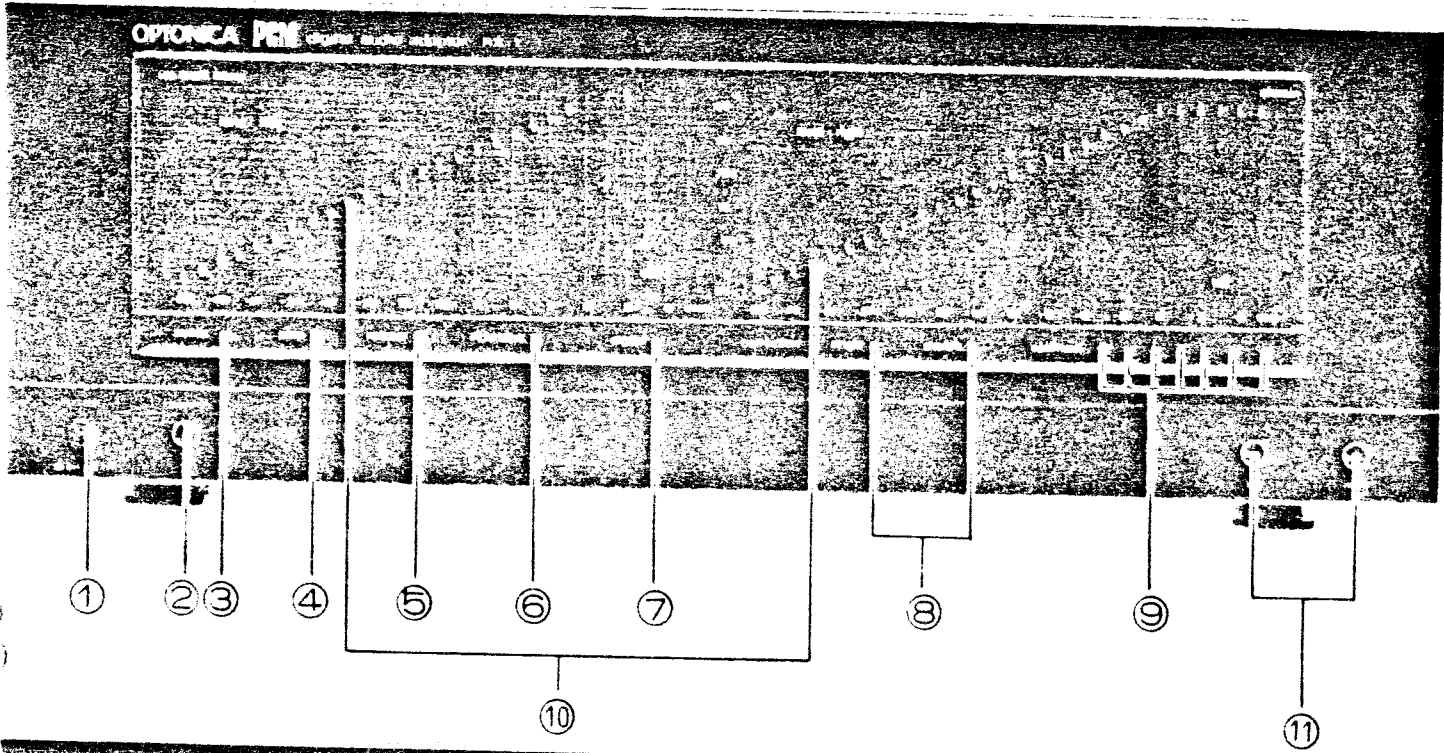



## CONTROLS AND FUNCTIONS

- 1. Power switch**  
Push in the switch to "on" position, and push it in again to "off" position.
- 2. Headphone jack**  
Accepts any headphone with 8-ohm impedance.
- 3. Power indicator**  
Lights up when the power is "on".
- 4. Playback indicator**  
Lights up when mode switch 12 is in "play" position.
- 5. Record indicator**  
Lights up when mode switch 12 is in "record" position.
- 6. PCM Tape indicator**  
The lamp indicates the PCM Tape (similar to a video cassette tape) is being played back.
- 7. Anti-Digital dubbing indicator**  
Some PCM Tapes have anti-dubbing signals that interfere with digital dubbing. The indicator shows the existence of such signals on the tape, and dubbing is therefore inoperative.
- 8. Error correction signal indicators**  
These show the level of signal correction being made on the prerecorded PCM tapes. A "single" lamp will light up when signal correction is made once. If two signal corrections are being made, both the "single" and "double" lamps will light up.
- 9. Optimum indicators**  
The fewer the indicators are on, the better the playback condition when using a PCM Tape. When several indicators are on, turn the optimum control knob clockwise or counter-clockwise to obtain the best condition.
- 10. LED level indicators**  
Recording or playback levels on each channel are monitored. Level setting differs from the conventional method. It is recommended that the average input level be set around  $-9\text{dB}$ ; never let the "over" indicator light up.
- 11. MIC input jack**  
Accepts low impedance microphones in right and left channels.
- 12. Mode (Record/Play) switch**  
Select either Record or Play mode with this switch.
- 13. Error monitor switch (Two-way monitor switch)**  
Push it to "source" position for monitoring both recording and playback performance by headphones. "Check" position is for monitoring and checking tracking, optimum control level, or dropouts when using a video cassette recorder.
- 14. Headphone volume control**  
Controls output level for headphones. Variable volume control does not affect recording level.
- 15. Line output level control**  
Controls playback output of the taped source. Set the control knob to maximum when using an amplifier. Level indicators show the fixed output, regardless of output level control operation.

16. **Line input level control**  
Controls input level from a home stereo system or a tape deck.
17. **MIC input level control**  
Controls input level from microphones.
18. **Optimum control**  
Maintains the digital adaptor at optimum playback condition when used with any video cassette recorder. It compensates a minor performance deviation in video cassette recorders.
19. **Line input terminal (phono jack)**  
Connects Record out or Line out terminals of an amplifier. Never use this terminal and Line input terminal (21) (cannon type connector) simultaneously!
20. **Line output terminal (phono jack)**  
Connects Tapé playback or Line in terminals of an amplifier.
21. **Line input terminal (cannon XLR-3-31 type unbalanced connector)**  
Use this terminal for connecting a microphone mixer or other professional audio equipment. Never use this input terminal and Line input terminal (19) (phono jack) simultaneously!  
The number three pin is a hot wire.
22. **Line output terminal (cannon XLR-3-32 type unbalanced connector)**  
Use this terminal for connecting Line output of professional type amplifiers.
23. **Digital input/output terminal**  
Use this terminal for connecting another RX-11 digital adaptor's input/output terminal when digital dubbing is performed by using two RX-11 digital adaptors and two video cassette recorders.
24. **Video input terminal**  
Use this terminal for connecting the video output terminal of a video cassette recorder. Never use this video input terminal and PL-259 type video input terminal (26) at the same time!
25. **Video output terminal**  
Use this terminal for connecting the video input terminal of a video cassette recorder. Never use this terminal and the PL-259 type video output terminal (27) simultaneously!
26. **Video input terminal (PL-259 type connector)**  
Use this terminal for connecting the PL-259 type video output terminal of a video cassette recorder. Never use this terminal and an additional video input terminal (24) simultaneously!
27. **Video output terminal (PL-259 type connector)**  
Use this terminal for connecting the PL-259 type video input terminal of a video cassette recorder. Never use this terminal and an additional video output terminal (25) simultaneously!
28. **Dubbing output terminal**  
Use this terminal when dubbing is performed by using this digital adaptor and two video cassette recorders. Connect it to the video input terminal of the recording video cassette recorder.
29. **External sync output terminal (phono jack)**  
Connect to the external sync input terminal of a video cassette recorder.
30. **External sync output terminal (PL-259 type)**  
Connect to the PL-259 type external sync input terminal of a video cassette recorder.

## PLAYBACK

Refer to the owner's manual for the operation of a video cassette recorder.

1. Make connections as illustrated: see diagram [2]-[3].
  2. Push "on" the power switch (1).
  3. Switch the mode selector to "play" position.
  4. Load a PCM tape into a video cassette recorder.
  5. Set the video cassette recorder's tracking control knob to auto position, or to the center position if manually set.
  6. Connect a headphone to the headphone jack (2).
  7. Playback the video cassette recorder and set the error monitor switch (two-way monitor switch) to "check" position.
  8. Adjust optimum control by monitoring optimum indicators.
  9. Obtain maximum tracking control by listening to the checking signals.
  10. Now, the tape can be played back anytime.
- During optimum control or tracking control, turn down the amplifier volume and set the monitor switch to the "monitor" position.
  - Once the initial optimum control and tracking control is adjusted, there is no further adjustment necessary as long as the video cassette recorder is used.
  - Always use a reliable video cassette recorder in excellent working condition in order to obtain maximum performance from the digital adaptor. Always keep the video heads clean.
  - When using a prerecorded PCM tape, make sure it complies with the PCM recording standard.

### Error Monitor Switch (Two-way Monitor Switch)

#### Source Position

- Recording and playback conditions are monitored by headphones when the switch is in "source" position.
  - When the switch is in "check" position, the headphones pick up the intermittent signal sound to indicate whether the optimum control or tracking control is properly set. The better the condition, the less audible the signal becomes. Usually, set the tracking control to "auto" position. When the signal sound becomes quick and clearly audible, the playback condition is poor. Proceed to set the tracking control manually to obtain the optimum playback condition. For manual settings, follow the instructions below:
1. Listen carefully to the signal sound. Count a number of signals audible within a period of five seconds. Turning of a tracking control knob will either increase or decrease signal interval. Set the knob where the least amount of signal is audible within a period of five seconds. Repeat this several times to obtain maximum tracking control.
- When the tracking control knob is turned, tracking is momentarily disturbed. When making an adjustment, wait until the tracking is stabilized and no continuous signal sound is heard.
- The signal sound is only reproduced by the headphone terminal (2) and it won't be reproduced through the speakers.
  - Every time a video cassette recorder/video cassette tape is changed, be sure to make tracking control and optimum control adjustments.
  - When recording, push back the switch to the "source" position.

## OPTIMUM CONTROL

This control maintains the optimum performance from the digital adaptor even when the video cassette recorder deviates from normal performance figures.

1. First, set this knob to the notched "middle" position.
  2. Optimum indicators will light up when a PCM Tape is played back. Less than two indicators will light up if the playback condition is favourable. When the playback condition is poor, several indicators will light up to show that the optimum control requires readjustment. Adjust the knob so that the fewest lamps will be illuminated.
- Readjust the knob each time a video cassette recorder/cassette tape is changed.
  - Since the performance characteristics of each video cassette recorder may vary, there may be cases when two to three indicators light up even if the playback condition is very good. All optimum indicators may light up right after a video cassette recorder is hooked to the digital adaptor. This does not indicate the machine is malfunctioning. Just playback the PCM Tape, and wait until the PCM Tape indicator is on before making any adjustment.

## RECORDING

Refer to the owner's manual for the operation of a video cassette recorder.

1. Make connections as illustrated: see diagram **1-2**.
  2. Push "on" the power switch (1).
  3. Switch mode selector (12) to "record" position.
  4. Adjust to proper recording level by turning the Line input control (16) knob or MIC input control (17) knob. Set the level indicator (10) for visual checking of input level.
  5. Load the video tape. Clear the tape counter to zero on the video cassette recorder. Press the record button.
- Since it takes several seconds for the video cassette recorder to be stabilized, wait several seconds before starting to record.
  - When the microphone is not used, turn the MIC input control knob to "0" position.
  - Always use reliable video cassette recorders in an excellent working conditions to obtain maximum recording performance from the digital adaptor. Always keep the video heads clean.
  - When recording, PCM Tape (optionally available) is recommended.
  - When recording is completed, let the video cassette recorder run for several seconds before disengaging the record button.
  - When recording right after the previously recorded programmes, let the video cassette recorder run in playback mode for several seconds before pressing the record button.

### Proper Recording Level

Set the average recording level at about -9dB.

1. Check the level indicators and adjust the Line input control (16) or MIC input control (17) to set the average recording level as close as possible to -9dB for a normal recording.
  2. Setting of the average recording level at more than -9dB produces good PCM recording results. But NEVER allow the "Over" level indicator to light up!
  3. Vary the average recording level below or over -9dB depending on the type of recording.
- Set peak recording level below the "OVER" level, but do not set it too low; otherwise a poor S/N ratio will result.

## DUBBING

There are basically three methods of dubbing using this digital audio adaptor.

### Dubbing Can Be Performed Using TV Signals

1. Push "on" the power switch.
  2. Switch the mode selector to play position.
  3. Playback the video cassette recorder. (refer to PLAYBACK section)
  4. Set to record mode on the video cassette recorder. (refer to PLAYBACK section)
  5. Dubbing is now in process.
- Adjusting Playback output control (15), Line input control (16), or MIC input control (17) does not affect recording level.

### Analog Dubbing

1. Push on the power switch (1).
2. Switch the mode selector (12) to "play" position on the playback digital audio adaptor.
3. Switch the mode selector (12) to "record" position on the recording digital audio adaptor.
4. Playback the source (playback) video cassette recorder. (refer to PLAYBACK section)
5. Set the record mode on the recording video cassette recorder. (refer to PLAYBACK section)
6. Now dubbing is in process.

### Digital Dubbing

1. Refer to diagram **6** for connections.
  2. Operation procedure is identical to the analog dubbing.
- There may be certain cases when using the TV signal will not produce good dubbing results. This is because there are minor performance deviations among video cassette recorders and video cassette tapes. If this is the case, perform analog or digital dubbing as explained earlier.



For live recordings : ..... Diagram I

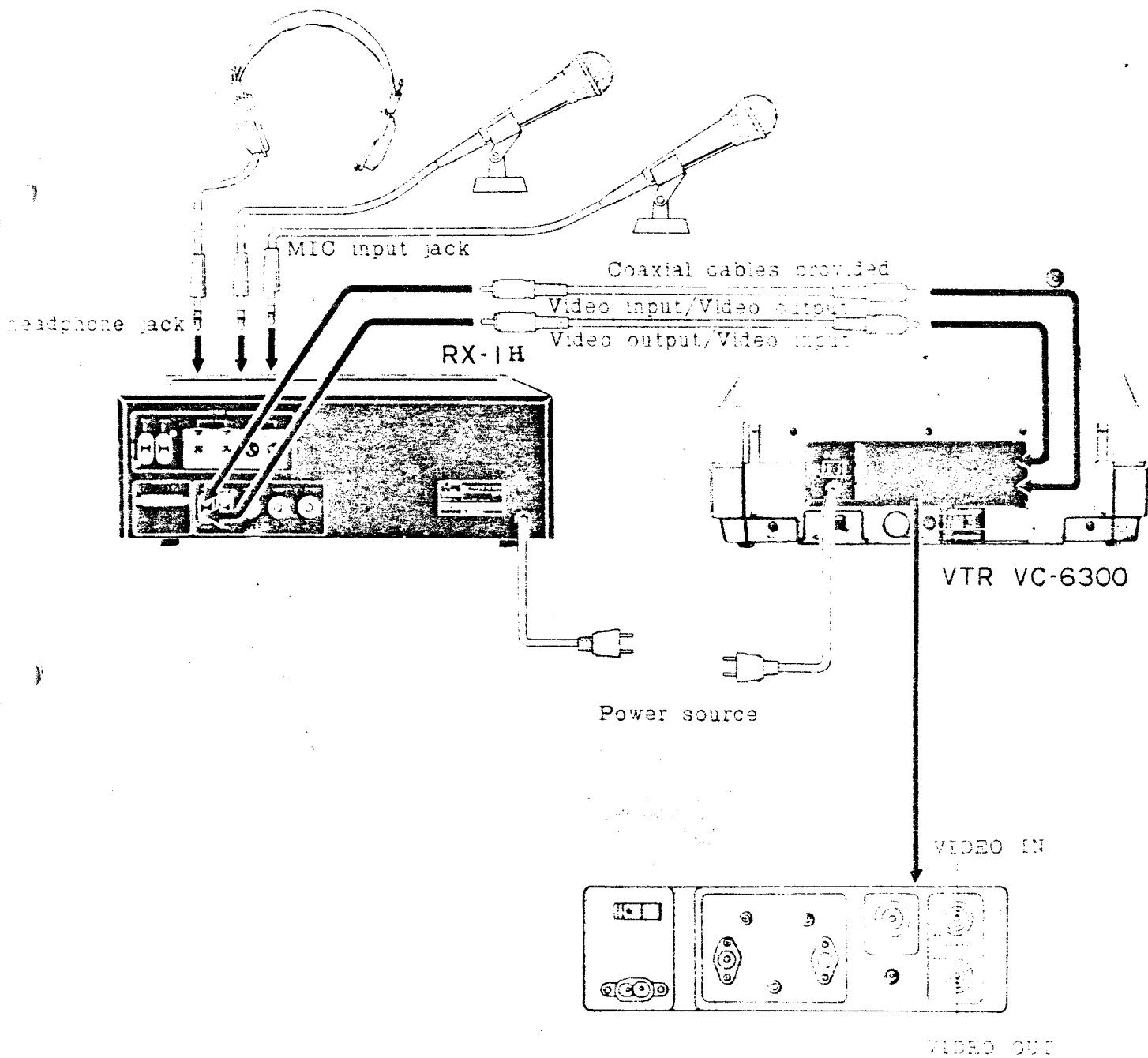

Recording from a record album, FM broadcast or tape recorder.  
and playback : ..... Diagram 2

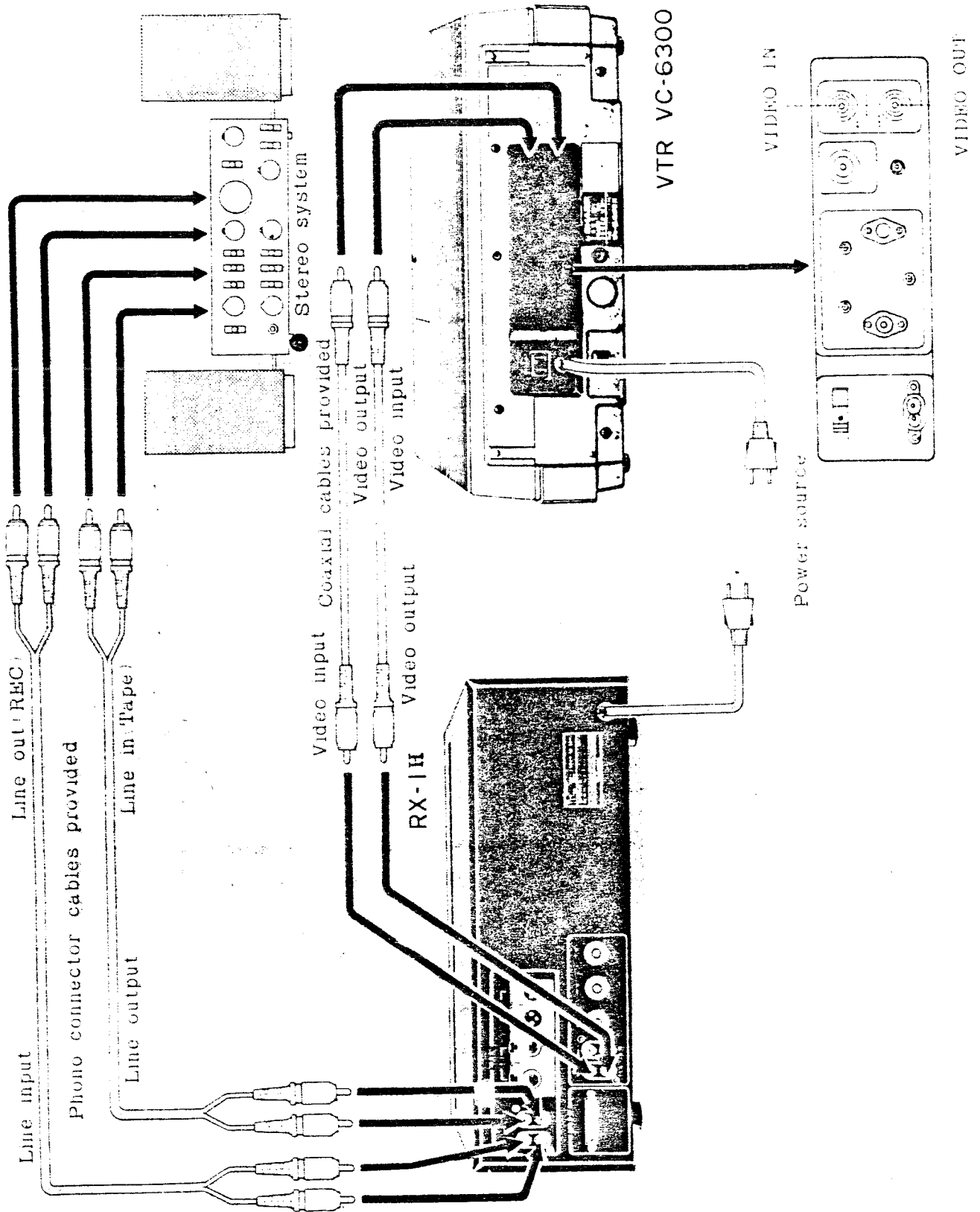

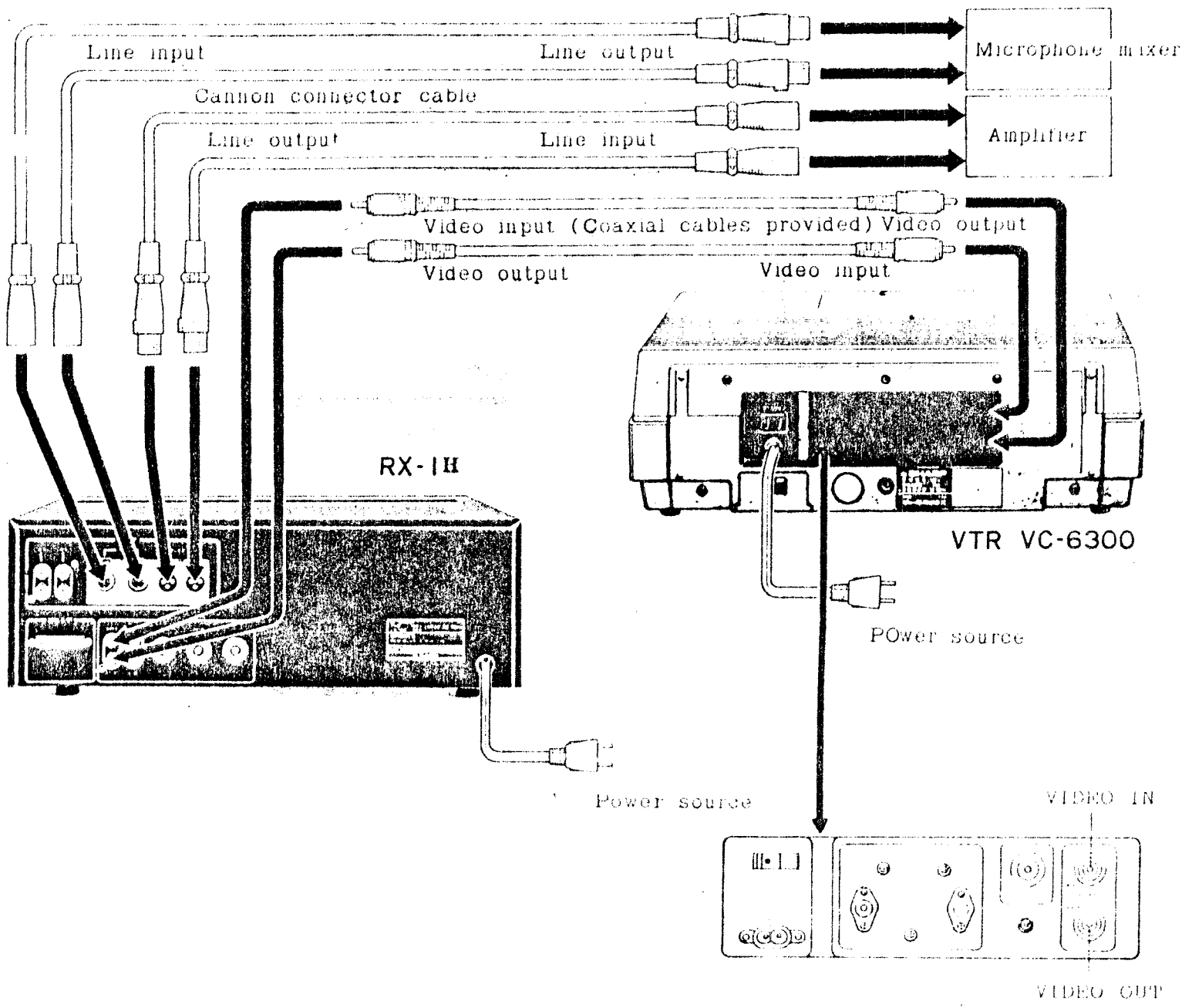

Connecting with professional equipment : ..... Diagram 3

TV signal dubbing connection: ..... Diagram 4

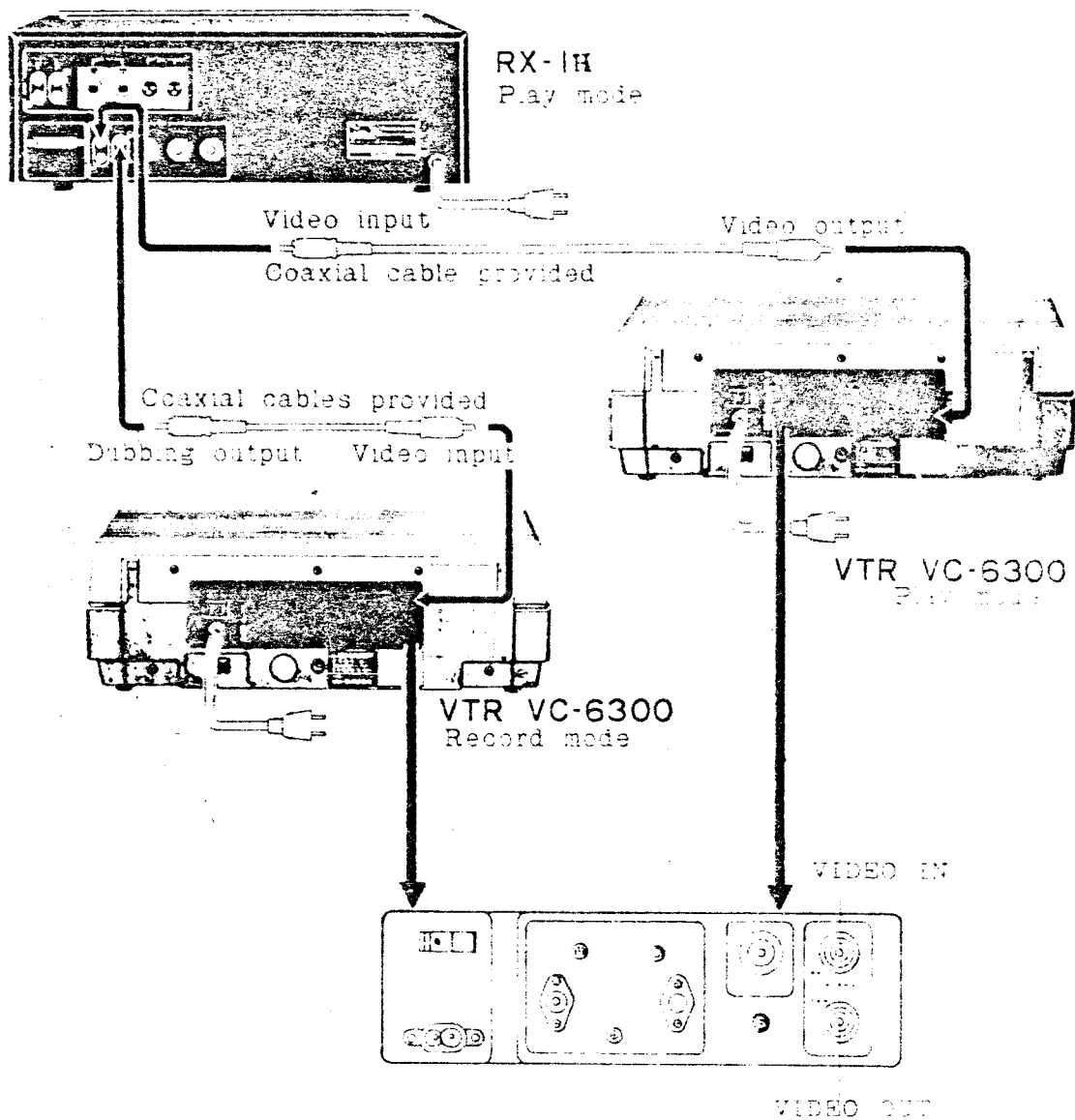

Analog dubbing connection: ..... Diagram 5

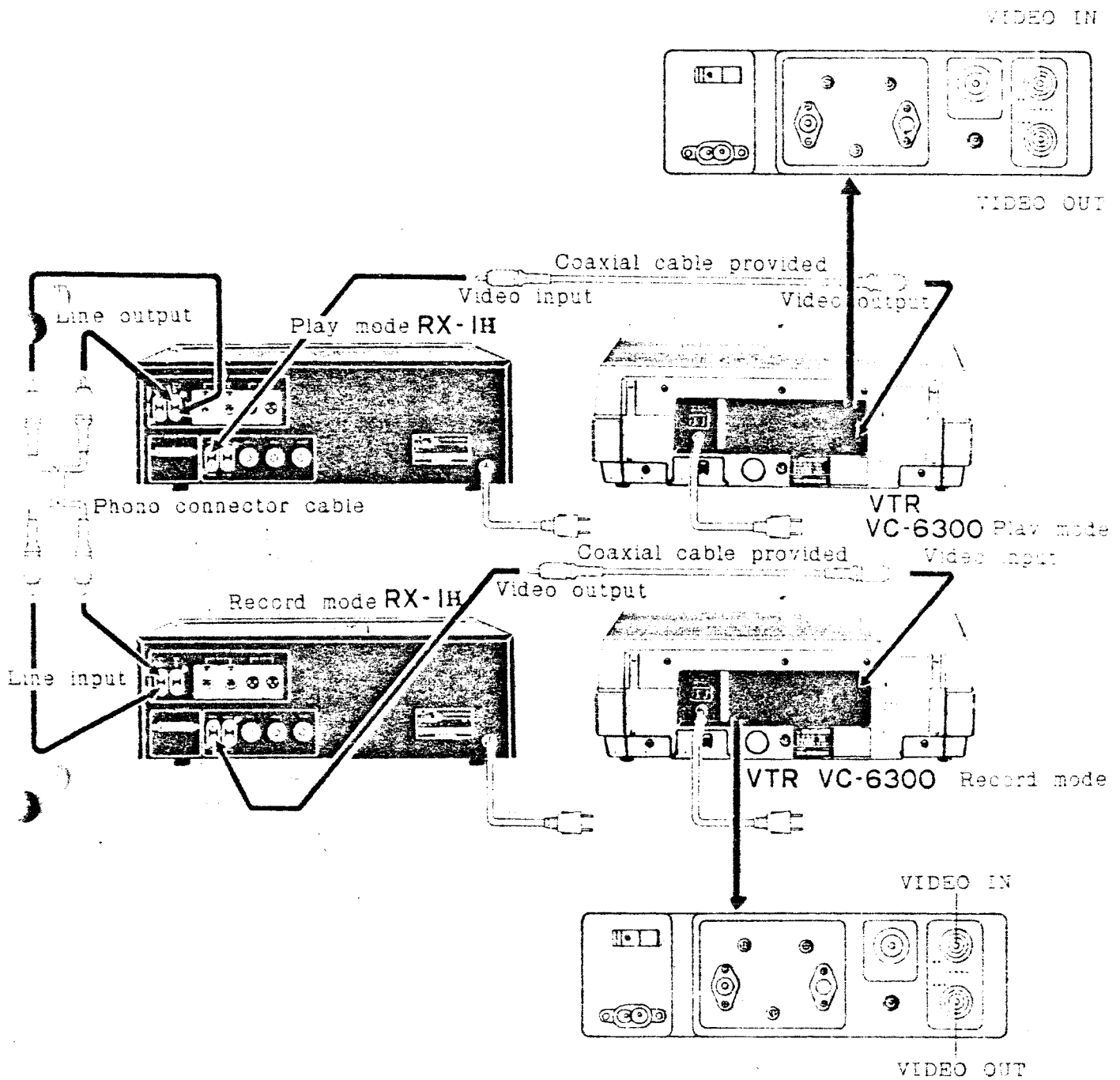



Digital dubbing connection : ..... Diagram 6

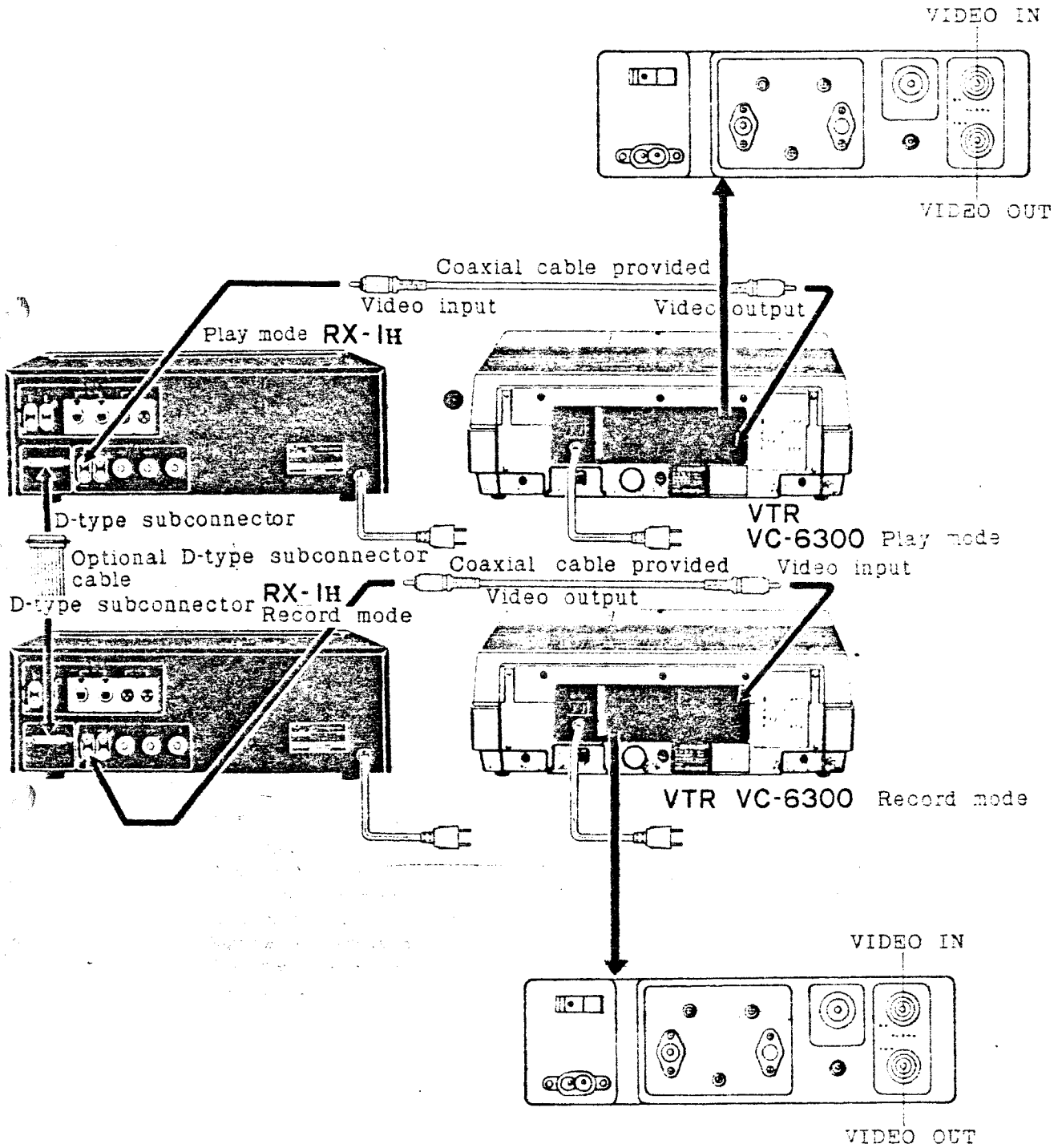

## SPECIFICATIONS

Power source:	AC 220V, 50Hz
Power consumption:	88 W
Dimensions:	430 (W) x 141 (H) x 360 (D)
Weight:	15.5 kg
Input terminals:	
MIC input terminal:	Low impedance microphone; Minimum input level, 3mV (-48dBm) or less.
Line input terminal:	Phone connector/cannon connector XLR-3-31 unbalanced; Minimum input level, 100mV (-18dBm) or less; Input impedance, 47k ohms.
Video input terminal:	Phono connector/PL-259 type connector; Input level, $1.0 \pm 0.2$ Vp-p (75 ohms termination).
Output terminals:	
Dubbing output terminal:	Phono connector; Output level, $1.0 \pm 0.2$ Vp-p (75 ohms termination); Output impedance, 75 ohms.
Line output terminal:	Phone connector/cannon XLR-3-32 connector, unbalanced; Output level, 500mV (-4dBm) or more for phono connectors, 1.23V (+4dBm) or more for cannon connectors; 600-ohm loaded impedance; Matching loaded impedance, 10k ohms or more for phono connector, 600 ohms or more for cannon connectors.
Video output terminal:	Phono connector/PL-259 connector. Output level, $1.0 \pm 0.2$ Vp-p (75 ohms termination); Output impedance, 75 ohms.
External sync output terminal:	Phono connector/PL-259 connectors; TTL level.
Digital input/output terminal:	D-type subconnector; TTL level.
Auxiliary Video Cassette recorder:	Sharp VC-6300 (VHS format); Beta format; U-matic format.
Frequency response:	2 - 20,000Hz
Dynamic range:	90dB
Harmonic distortion:	0.03% (1kHz)
Wow & flutter:	Below measurable value.
Level variation:	Below measurable value.
Crosstalk:	More than 60dB.
Error correction capability:	99.995%
Standard:	EIAJ standard (625 line)
Recording format:	PCM recording in 625 line standard TV signals.
Transmission channels:	Two channels.
Sampling frequency:	44.1kHz
Number of quantizing bit:	14-bit
Data transmission rate:	2.625Mops-
Accessories:	Phono type connecting cable; Phono type/PL-259 type coaxial cable x 2 (75 ohms); Owner's manual.

- Specifications are subject to change without notice.
- The manufacturer reserves the right to vary specifications, design, or use alternative materials as may be deemed necessary or desirable at any time, any such change or variation being of a kind as not to reduce the quality, performance or appearance.